

# SECTION 7 - SUSPENSION

---

---

## TABLE OF CONTENTS

---

Front and Rear Suspension Assembly	
Schematics.....	7-2
Shock Absorbers .....	7-2
Swing Arm.....	7-5
Front A-Arms.....	7-10
Wheels and Tires .....	7-15



# Front and Rear Suspension Assembly Schematics

## FRONT SUSPENSION

### KEY

1. Shock Absorber
2. Cap Screw
3. Cap Screw
4. Nut
5. A-Arm
6. A-Arm
7. Bearing
8. Bearing
9. Dust Seal
10. Dust Seal
11. Spacer
12. Spacer
13. Cap Screw
14. Nut
15. Washer

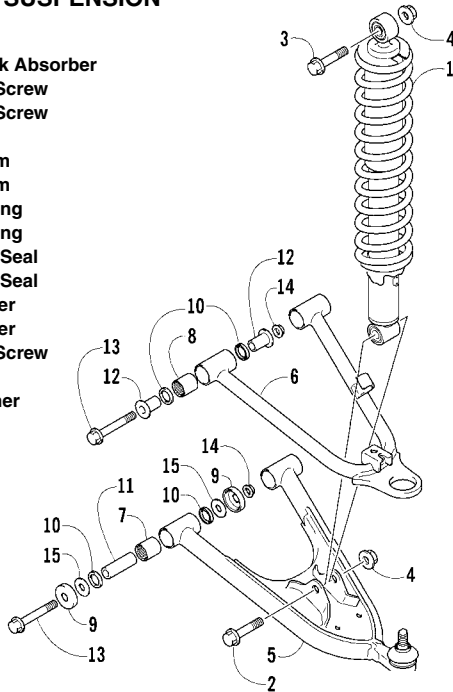

0739-246

## REAR SUSPENSION

### KEY

1. Front Arm Assy
2. Bearing
3. Bearing
4. Grease Fitting
5. Spacer
6. Dust Seal
7. Cap Screw
8. Nut
9. Spacer
10. Spacer
11. Cap Screw
12. Dust Seal
13. Spacer
14. Guard
15. Screw
16. Rear Arm
17. Spacer
18. Cap Screw
19. Nut
20. Cap Screw
21. Shock Absorber
22. Nut
23. Cap Screw

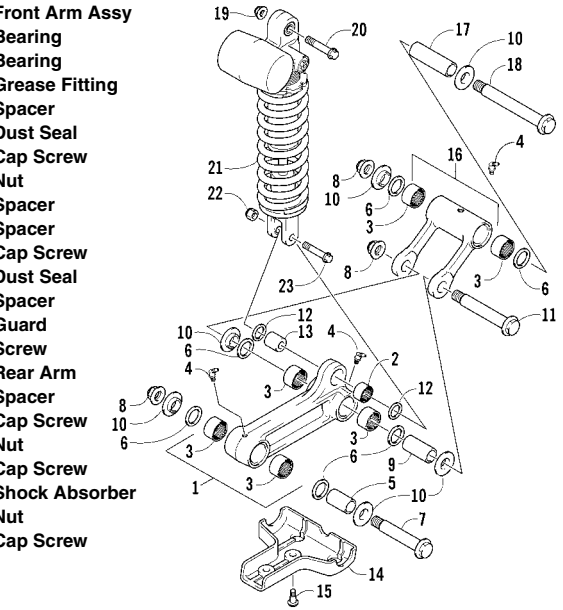

0739-252

## SWING ARM

### KEY

1. Swing Arm Assy
2. Bearing
3. Bushing
4. Seal
5. Spacer
6. Dust Cover
7. Washer
8. Pivot Shaft
9. Nut
10. Chain Slide
11. Cap Screw
12. Adjuster Plate
13. Adjuster Bolt
14. Washer
15. Circlip
16. Nut
17. Cap Screw
18. Cap Screw
19. Washer
20. Plate
21. Plate
22. Guard Assy
23. Guard
24. Chain Slide
25. Washer
26. Rivet
27. Cap Screw
28. Cap Screw
29. Washer
30. Cap
31. Boot

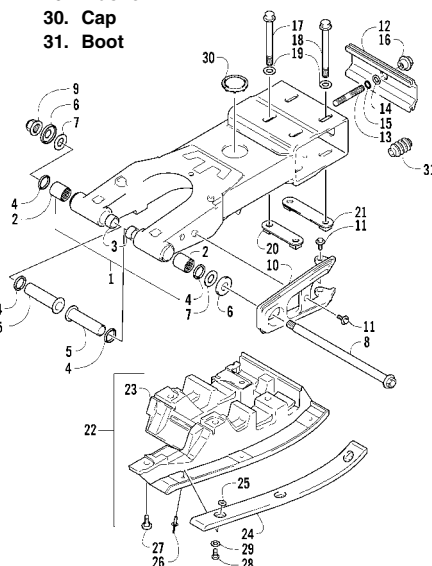

0739-251

## Shock Absorbers

### REMOVING FRONT SHOCKS

1. Secure the ATV on a support stand to elevate the wheels and to release load on the suspension.

### **⚠ WARNING**

**Make sure the ATV is solidly supported on the support stand to avoid injury.**

2. Remove the cap screws and nuts securing each front shock absorber to the A-arm and frame.



AF730D

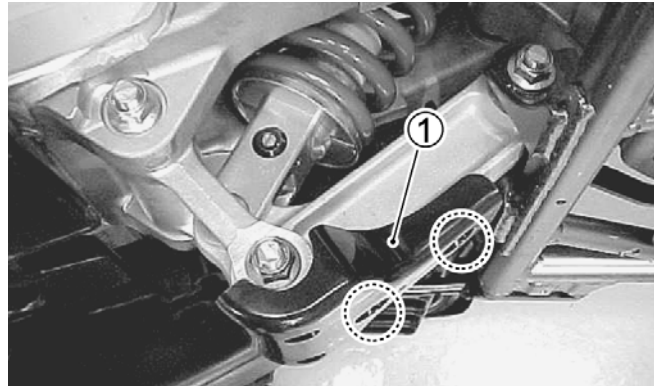

SP325

## CLEANING AND INSPECTING

■ **NOTE:** Whenever a part is worn excessively, cracked, or damaged in any way, replacement is necessary.

1. Clean all shock absorber components in parts-cleaning solvent.
2. Inspect each shock rod for nicks, pits, bends, and oily residue.
3. Inspect the springs, spring retainers, shock rods, shock bodies, and eyelets for cracks, leaks, and bends.

## INSTALLING FRONT SHOCKS

1. Place the shock absorber spring over the shock absorber, compress the spring, and install the retainer.
2. Install each shock absorber to the frame and A-arm with cap screws and nuts. Tighten all nuts to specifications.

### CAUTION

Do not tighten the nut beyond the recommended specification or the shock eyelet or mount **WILL** be damaged.

3. Remove the ATV from the support stand.

## REMOVING REAR SHOCK

1. Secure the ATV on a support stand to elevate the wheels and to release load on the suspension.

### WARNING

Make sure the ATV is solidly supported on the support stand to avoid injury.

2. Remove the rear arm guard (1); then remove the swing-arm guard (2).

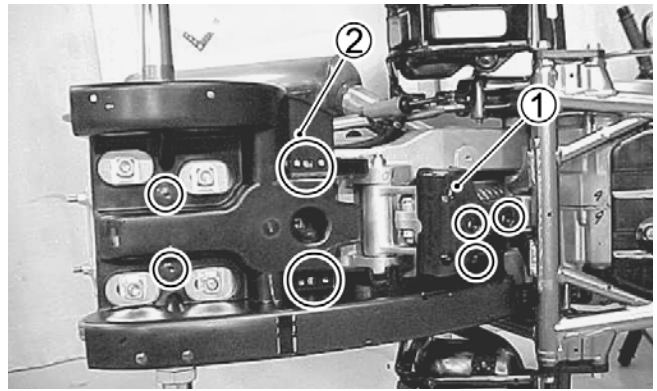

SP326

3. Remove the rear arm lower nut and cap screw (3); then remove the shock absorber nuts and cap screws (4-5).

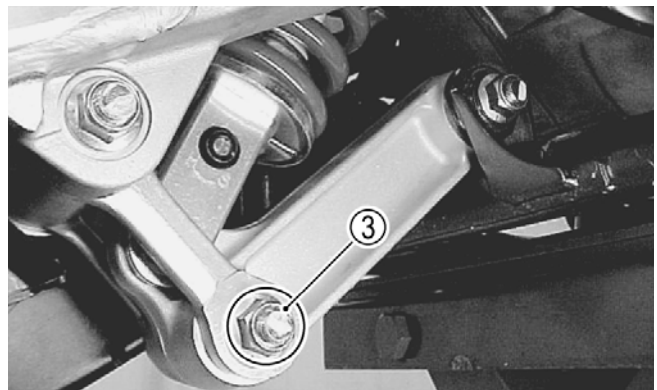

SP327



SP328

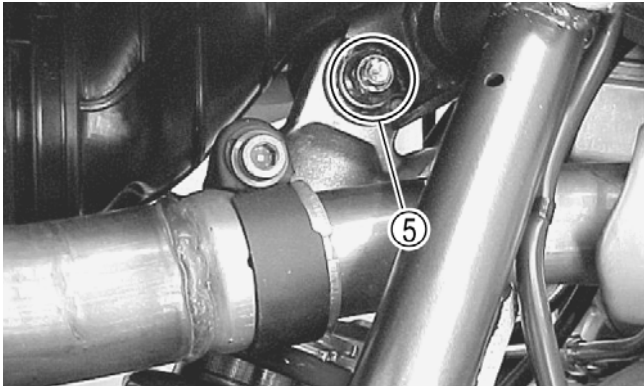

SP329

- Remove the rear shock absorber by lifting up the swing-arm and lowering the shock absorber assembly.

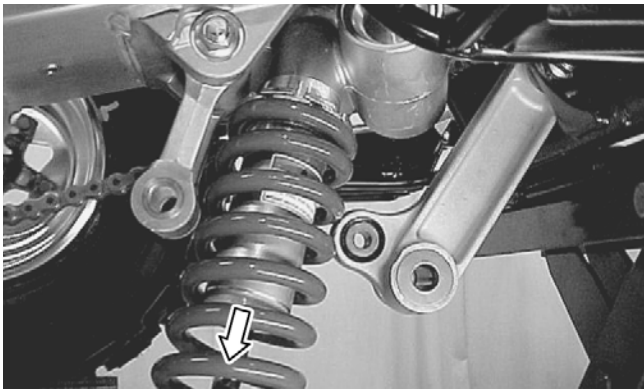

SP330

## CLEANING AND INSPECTING

- Clean the shock absorber in parts-cleaning solvent.
- Inspect each shock absorber body and rubber bushing for damage and leaking oil. If any defects are found, replace the shock absorber.

### **⚠ WARNING**

**Do not attempt to disassemble the rear shock absorber. It contains high-pressure nitrogen gas and is not serviceable.**

■ **NOTE:** Do not dispose of the shock absorber until the high-pressure nitrogen gas is released.

## RELEASING GAS PRESSURE

Remove the valve cap; then using a screwdriver, depress the valve releasing the gas.

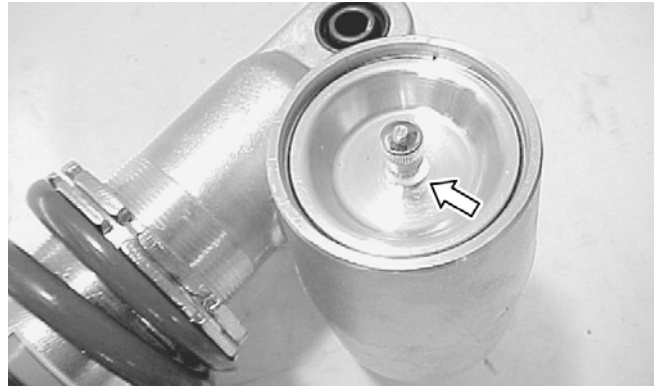

SP331

### **⚠ WARNING**

**Direct the valve stem away from your body. Always wear protective eyewear when releasing high-pressure gas.**

## INSTALLING REAR SHOCK

- Raise the swing-arm and place the shock absorber in position; then install the upper and lower cap screws and nuts.
- Tighten the upper nut (1) and the lower nut (2) to specifications.



SP332A

- Install the rear arm lower cap screw and nut; then tighten the nut to specifications.

## ADJUSTING SPRING PRELOAD

The rear spring preload is adjustable by changing the spring set length. Using the following procedure, adjust the spring.

- Remove the rear shock absorber; then secure the shock absorber in a suitable holding fixture or vise.
- Loosen the lock nut (1); then adjust the spring set length by turning the adjuster (2).

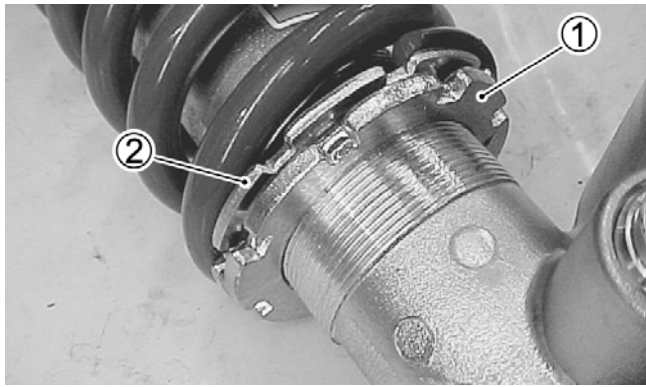

SP334

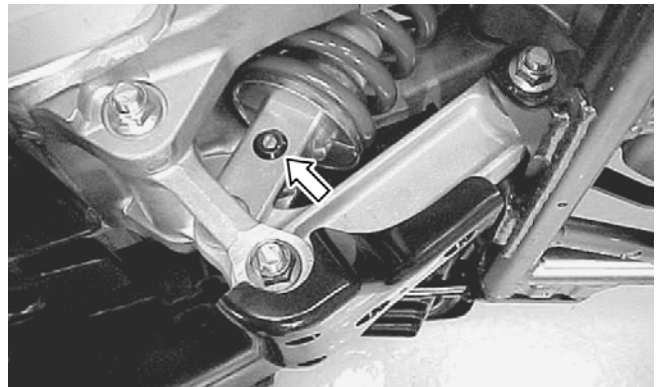

SP336

SPRING SET LENGTH		
STANDARD	MAXIMUM (SOFTTEST)	MINIMUM (STIFFEST)
233 mm (9.17 in.)	238 mm (9.37 in.)	228.5 mm (9.00 in.)

**⚠ WARNING**  
Do not adjust the spring preload out of the specified range.

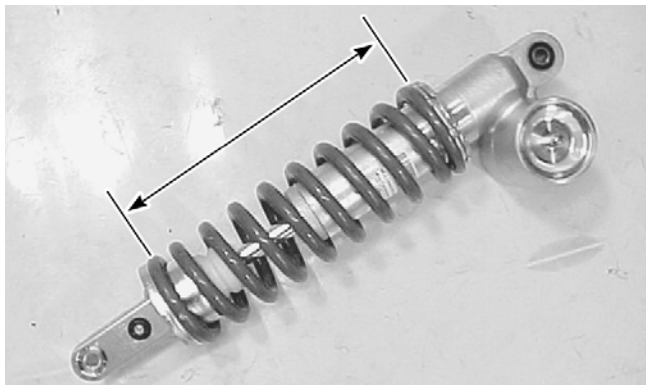

SP335

2. Turn the adjuster 16 clicks counterclockwise for the “standard” setting.

### Compression

1. Turn the upper damping force adjuster screw fully clockwise.

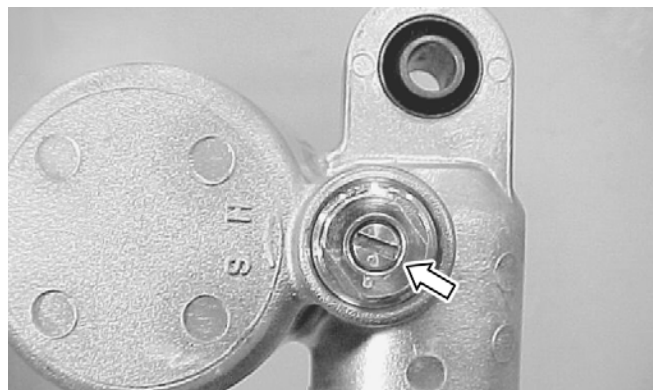

SP337

2. Turn the adjuster two full turns counterclockwise for the “standard” setting.

3. Tighten the lock nut securely; then install the shock absorber assembly.

### ADJUSTING DAMPING FORCE

The compression and rebound damping forces are adjustable. To adjust, use the following procedure.

■ **NOTE:** Do not force the damping adjuster screws or tighten them; damage to the adjusters will occur.

■ **NOTE:** Turning the adjuster screws clockwise increases force; turning them counterclockwise decreases force.

#### Rebound

1. Turn the lower damping force adjuster screw fully clockwise.

## Swing Arm

### REMOVING AND DISASSEMBLING

1. Secure the ATV on a support stand to elevate the wheels and to release load on the suspension.

**⚠ WARNING**  
Make sure the ATV is solidly supported on the support stand to avoid injury.

2. Remove the swing arm guard (1); then remove the rear arm guard (2).

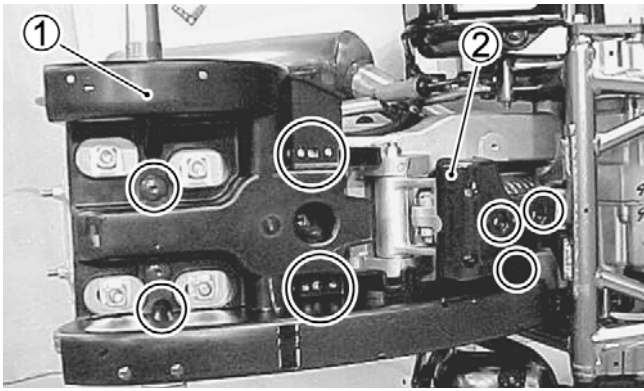

SP338

3. Remove the rear arm (3); then remove the front arm (4).

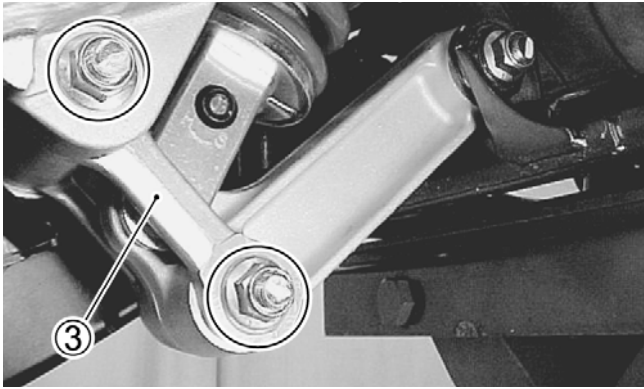

SP339

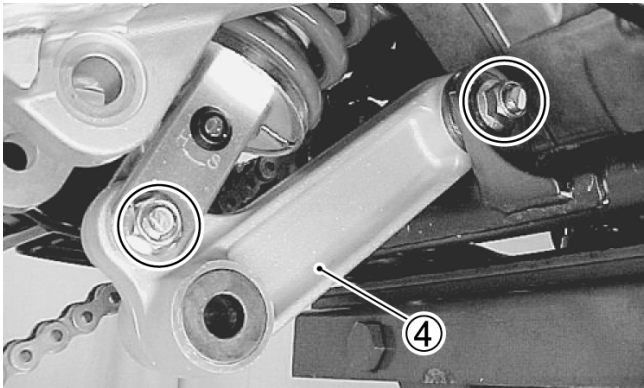

SP340

4. Remove the shock absorber; then remove the rear wheels.

5. Remove the axle housing (see Section 6).

6. Remove the brake hose guide (1); then remove the parking brake cable guide (2).

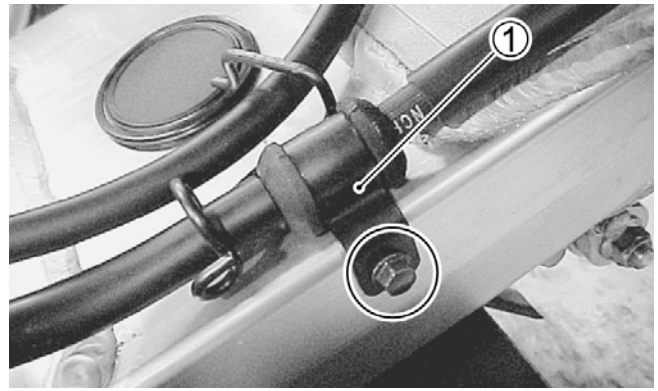

SP341

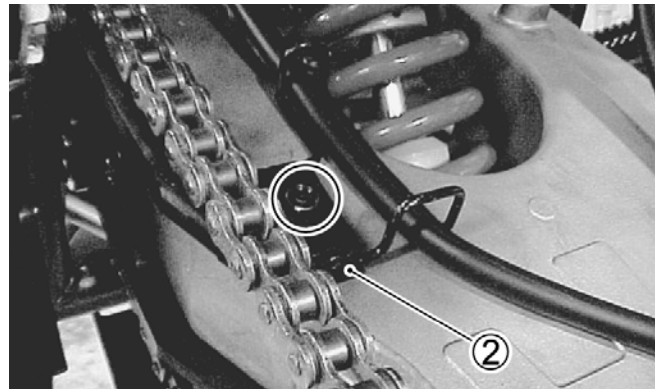

SP342

7. Remove the swing-arm pivot nut; then remove the swing-arm pivot shaft and remove the swing arm.

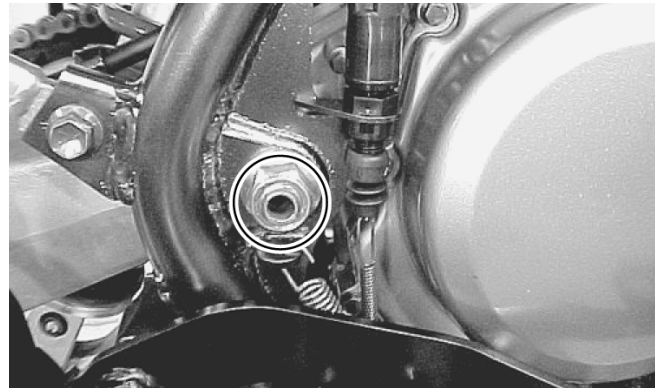

SP343

8. Remove the chain slide.

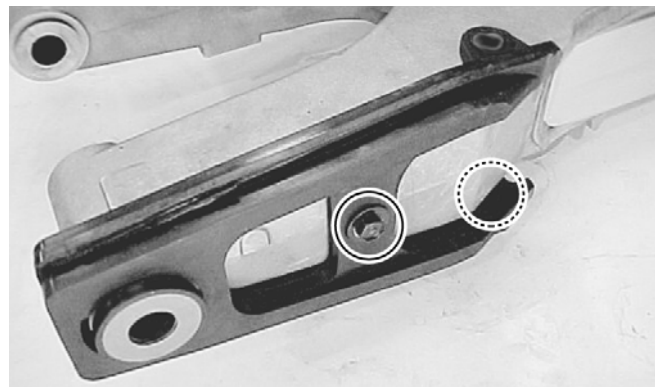

SP344

9. Remove the dust covers (1), washers (2), and spacers (3) from the swing arm; then remove the spacers from the front arm and rear arm.

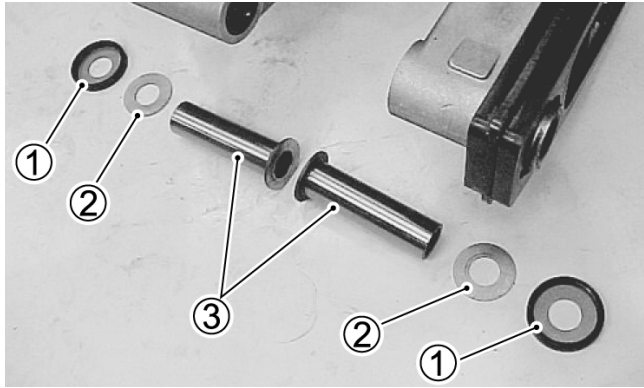

SP345

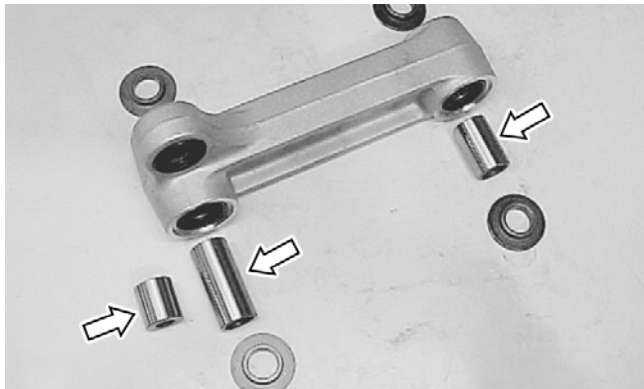

SP346

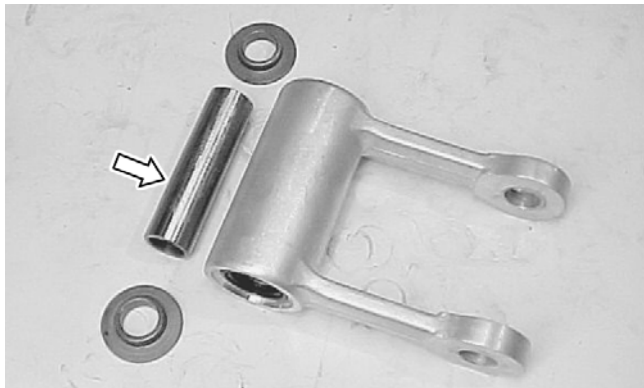

SP347

## CLEANING AND INSPECTING

■ **NOTE:** Whenever a part is worn excessively, cracked, or damaged in any way, replacement is necessary.

1. Inspect the dust covers, seals, and spacers for wear or damage. If any defect is found, they must be replaced.

2. To inspect swing-arm bearings and bushings, insert the spacer (1) into the bearing (2) and bushing (3); then check for excessive play by moving the spacer up and down. If excessive play is noted, the bearing must be replaced.

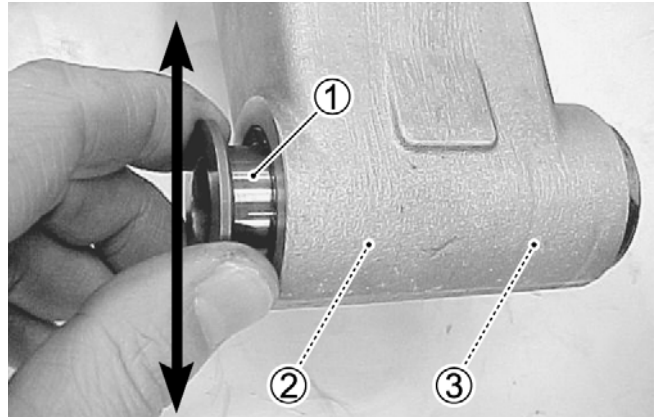

SP348

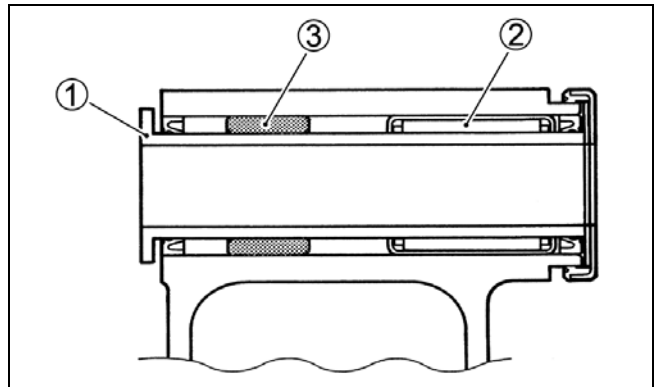

ATV2192

3. Remove the dust seals; then using a bearing remover and slide hammer, remove the worn bearings.



SP349

■ **NOTE:** Removed bearings must be replaced with new ones.

4. Using an appropriate bushing driver, remove the pivot bushing.

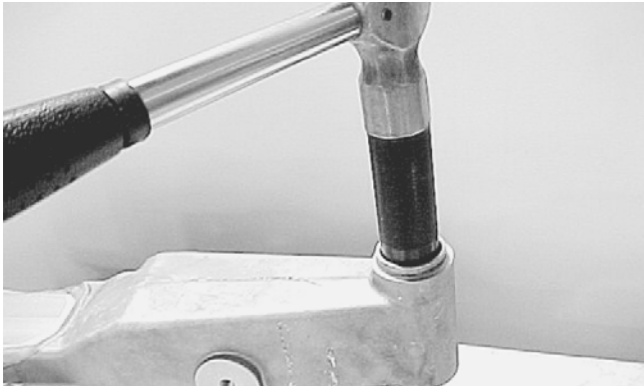

SP350

■ **NOTE:** Removed bushings must be replaced with new ones.

5. To inspect front and rear arm bearings, insert the spacer into the bearing; then check for excessive play by moving the bearing up and down. If excessive play is noted, the bearing must be replaced.

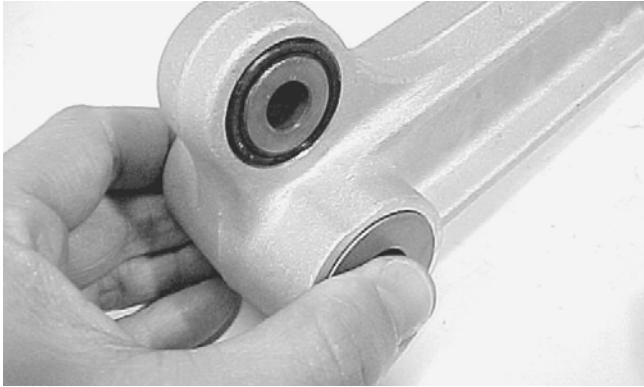

SP351

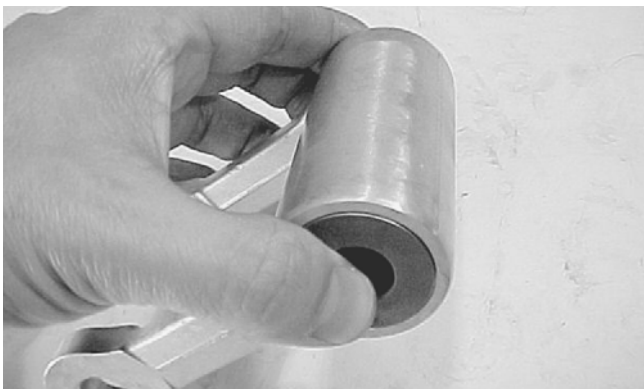

SP352

6. Remove the dust seals; then using a suitable bearing puller and slide hammer, remove the defective bearing.

■ **NOTE:** Removed bearings must be replaced with new ones.



SP353



SP354

7. Remove the front arm bearings using a suitable bearing puller set.

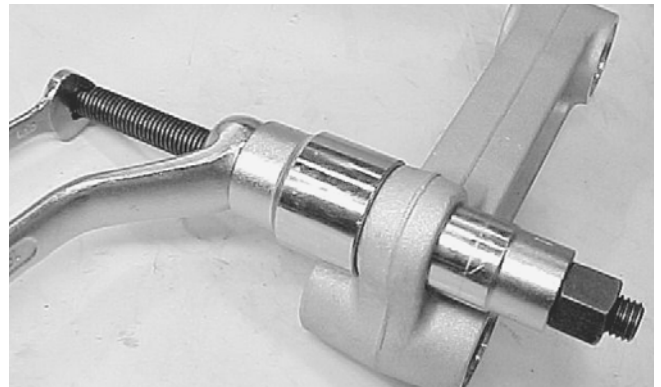

SP355

■ **NOTE:** Removed bearings must be replaced with new ones.

8. To check pivot shaft runout, use a dial indicator. If runout exceeds 0.3 mm (0.01 in.), replace the pivot shaft.



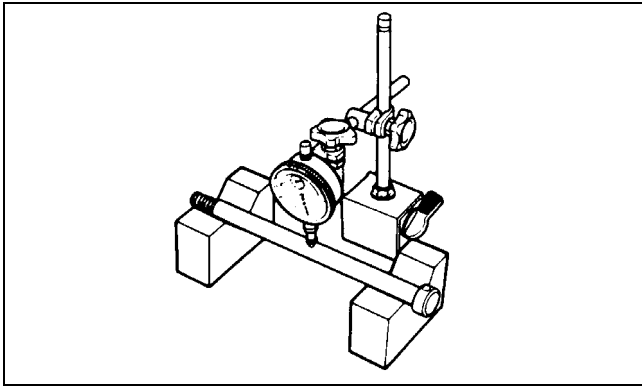

ATV2194

## ASSEMBLING AND INSTALLING

- Using a suitable bearing installer, press the new bearing into the swing arm pivot to a depth of 5 mm (0.2 in.); then press the bushing into the swing arm pivot to a depth of 12 mm (0.47 in.).

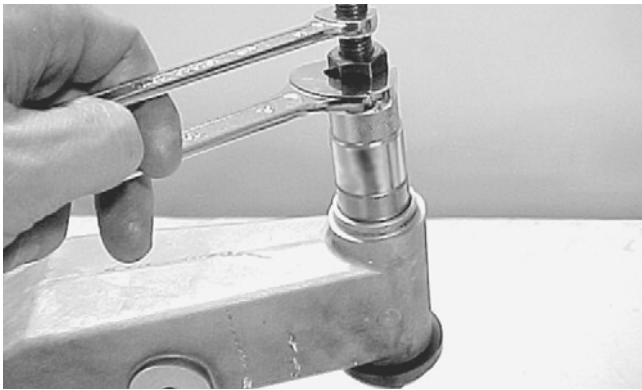

SP356

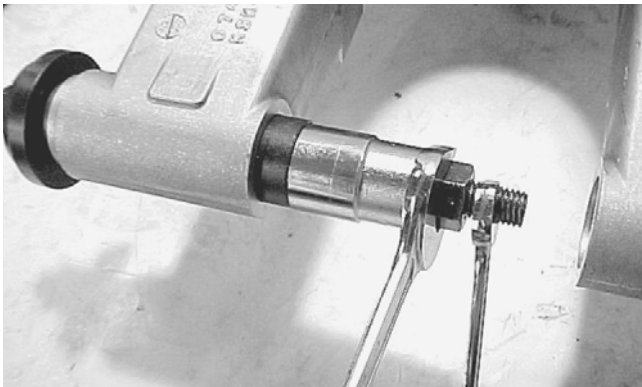

SP357

- Install the dust seals into the swing arm pivot with the stamped marks directed towards the outside; then lubricate the bearing, bushings, and seal lips with multipurpose grease.

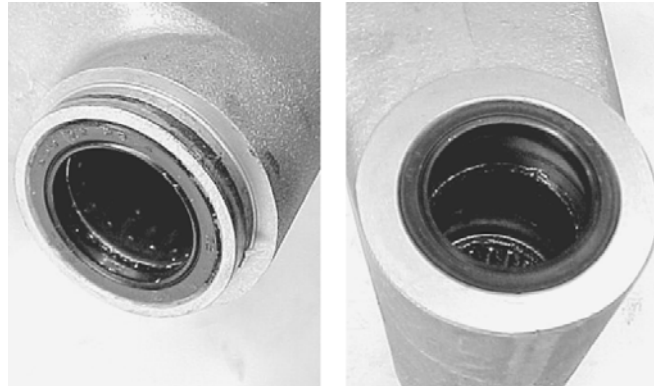

SP358A

- Apply multipurpose grease to the lip of the dust covers; then install the dust covers (1), washers (2), and spacers (3) to the swing arm.

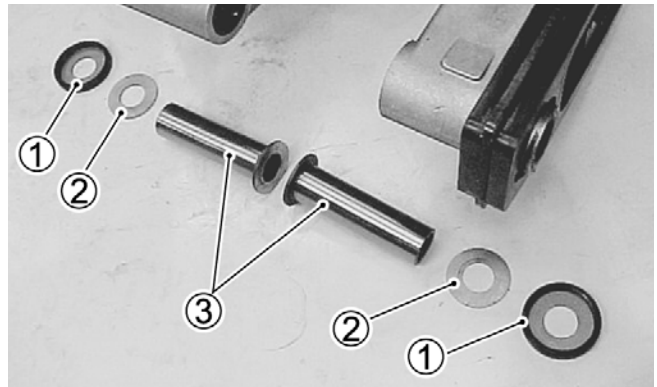

SP360

- Using a suitable bearing installer, install the new rear arm bearings to the specified depth; then install the dust seals coating the seal lips and bearings with multipurpose grease. See the illustration below for the proper bearing depths.

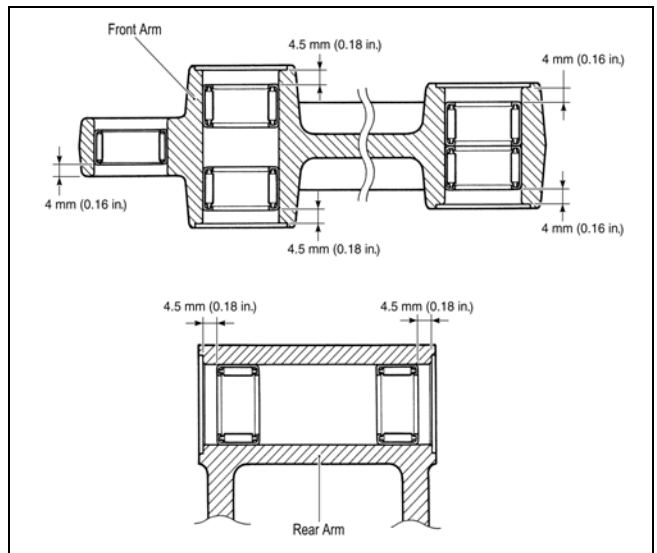

ATV2195

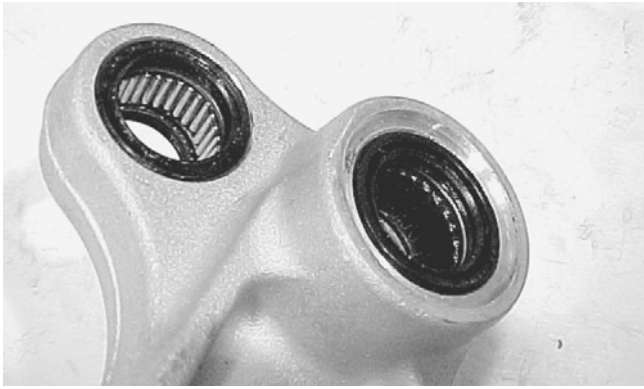

SP361

■ **NOTE:** The stamped mark of the dust seals must be directed toward the outside of the assemblies.

5. Install the swing arm and pivot shaft; then install the swing-arm pivot nut and tighten to specifications.

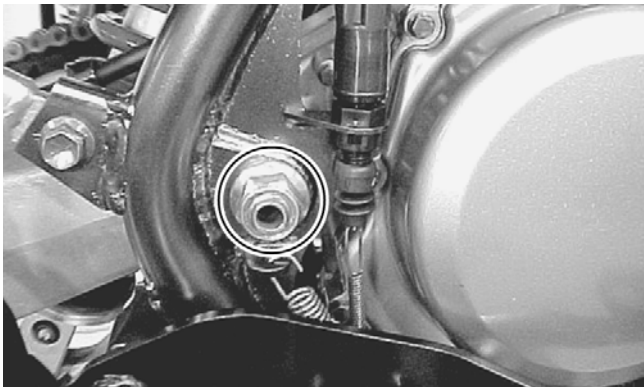

SP362

6. Install the rear shock absorber and front arm; then tighten the shock absorber mounting nuts (1 and 2) to specifications.

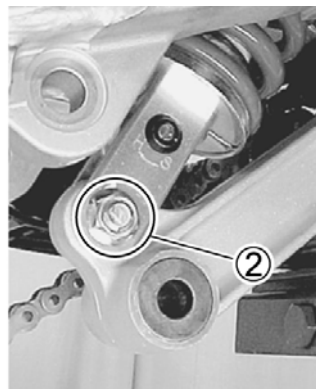
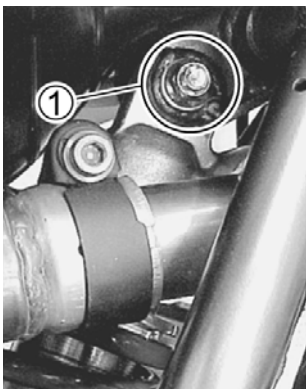

SP363A

7. Install the rear arm bolts and nuts; then tighten the nuts (3 and 4) to specifications.

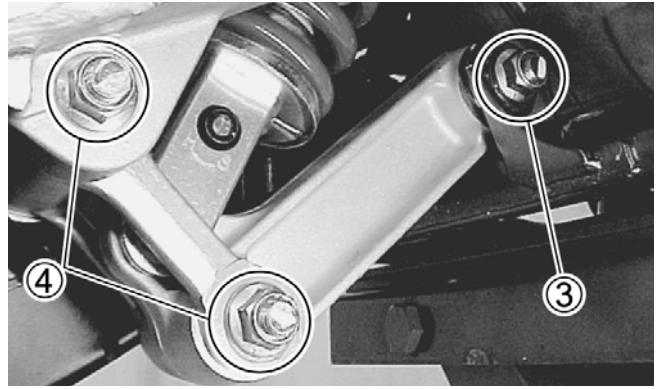

SP365

8. Install the rear arm guard and the swing-arm guard.

## Front A-Arms

### REMOVING

1. Secure the ATV on a support stand to elevate the front wheels; then remove a front wheel.

### **⚠ WARNING**

**Make sure the ATV is solidly supported on the support stand to avoid injury.**

2. Remove the cotter pin from the nut.

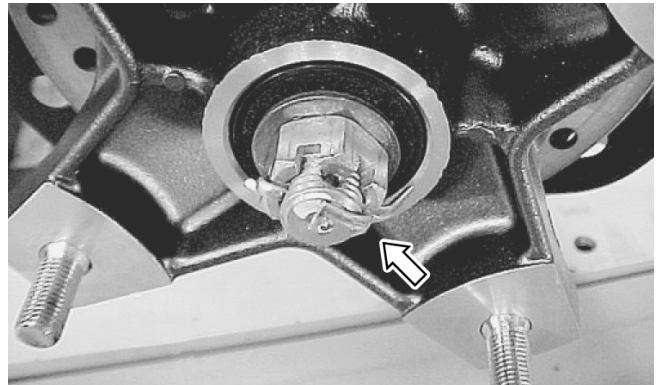

SP366

3. Remove the nut securing the hub. Account for a washer.
4. Remove the Allen-head screws (1) securing the brake caliper; then remove the caliper and lay aside.

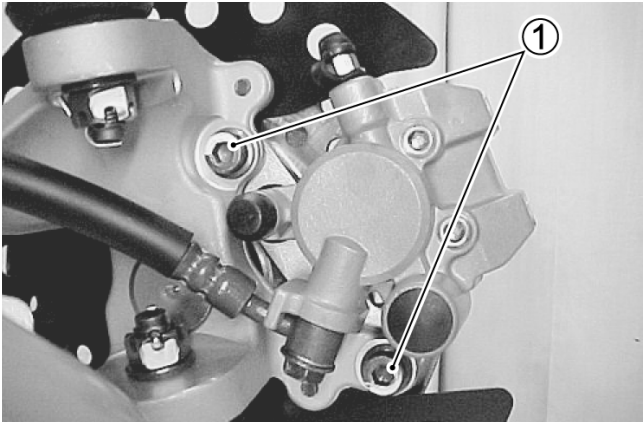

SP367

5. Remove the hub assembly; then remove the disc cover (2).



SP368

6. Remove the cotter pin and slotted nut securing the tie rod end to the knuckle; then remove the tie rod end from the knuckle.

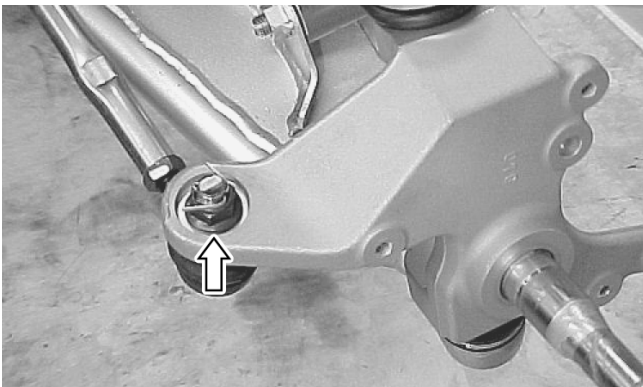

SP369

7. Remove the brake hose clamp (1); then remove the front bumper assembly (3).



SP370

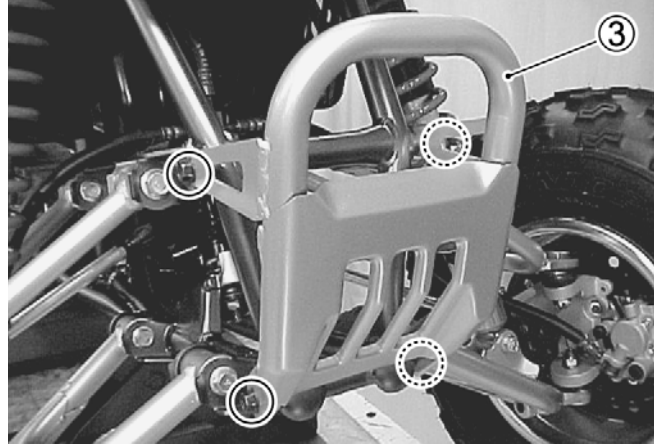

SP371

8. Remove the shock absorber lower mounting cap screw (4); then remove the arm assembly (5).

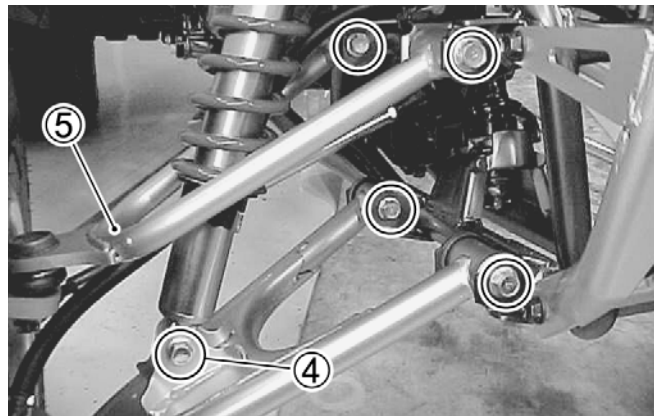

SP372

9. Remove the shock absorber; then remove the cotter pins and nuts from the ball joints.

7

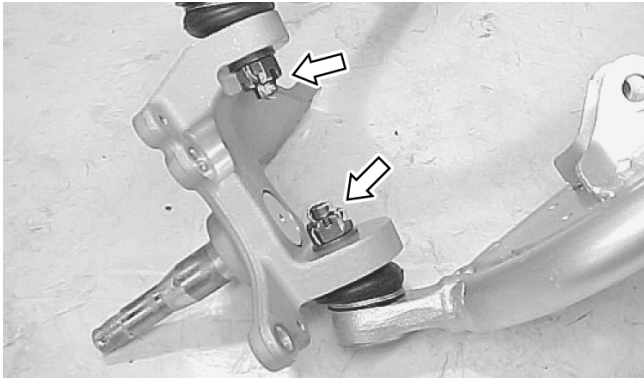

SP373

10. Using a ball joint remover (8), remove the ball joint from the knuckle (7).

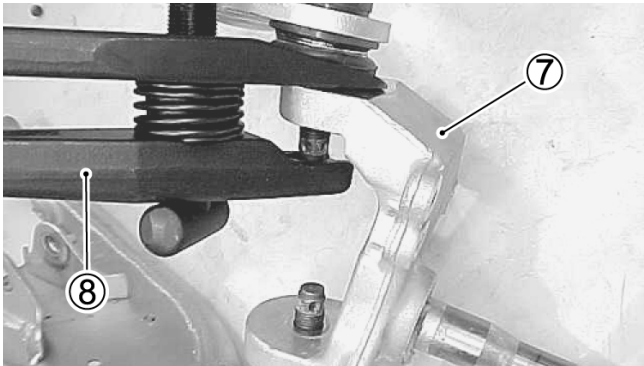

SP374

## CLEANING AND INSPECTING

1. Clean the knuckle in parts-cleaning solvent; then dry with compressed air. If any damage or excessive wear is detected, the knuckle must be replaced.



SP375

2. Inspect the ball joint for boot damage or wear. Remove the circlip and replace the ball joint if damage is found.

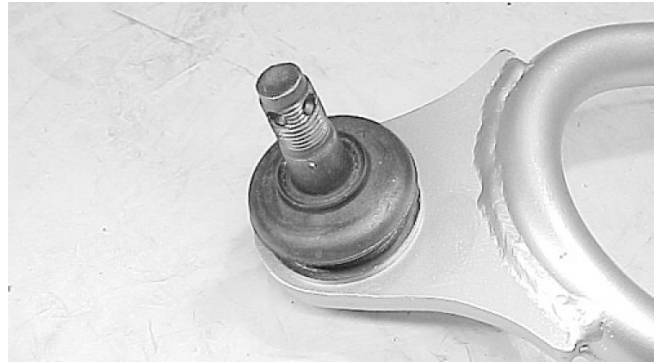

SP376

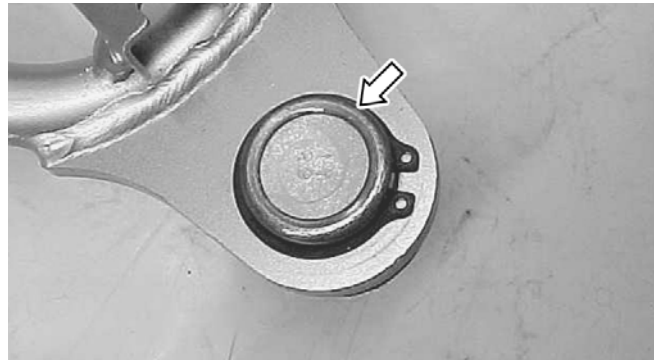

SP377



SP378

3. Inspect the arm for broken welds, cracks, or bends. Replace if damaged.



SP379

4. Remove the spacers and dust seals and inspect for damage to seal lips and spacers.

■ **NOTE:** The pivots are equipped with roller bearings. The bearing rollers may fall out when the spacers are removed.



SP380

5. Check the bearings for excessive wear and replace them if worn.



SP381

6. Using a suitable bearing remover, remove the pivot bearings; then clean all parts in parts-cleaning solvent.

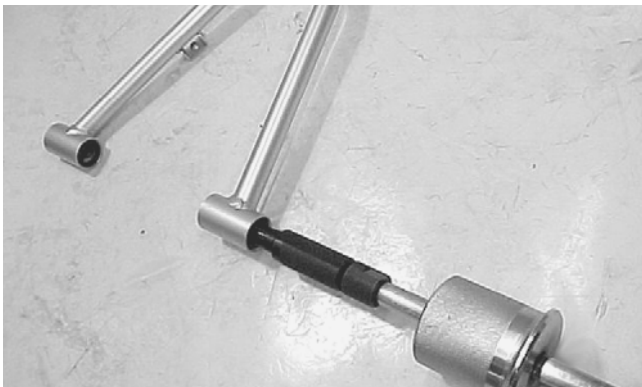

SP382

■ **NOTE:** All bearings, spacers, and seals that are removed must be replaced with new ones.

## INSTALLING

1. Using a bearing installer, install the ball joint in the arm; then install the circlip.



SP383

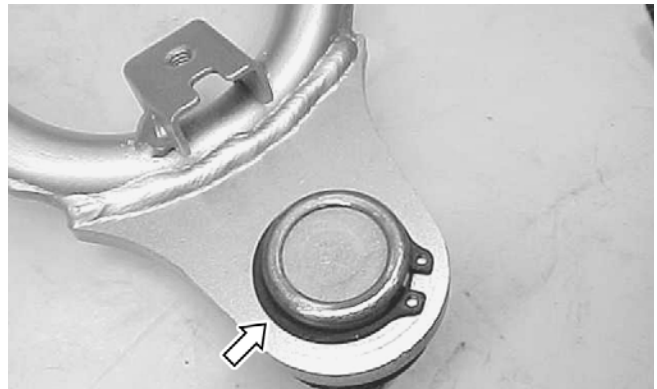

SP384

2. Install the bearings in the upper arm pivot to a depth of 12 mm (0.47 in.) with a bearing installer and suitable spacer. The stamped side of the bearing should be directed toward the spacer (1).

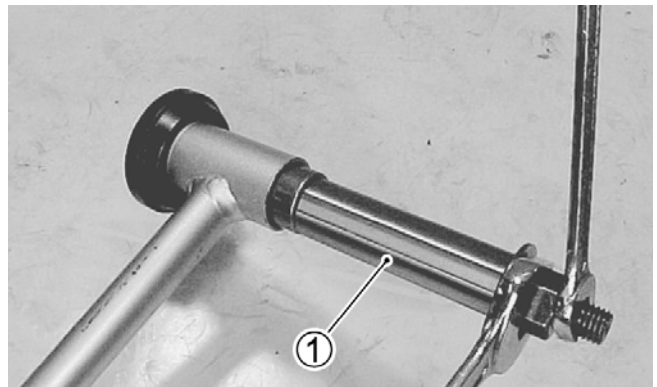

SP385

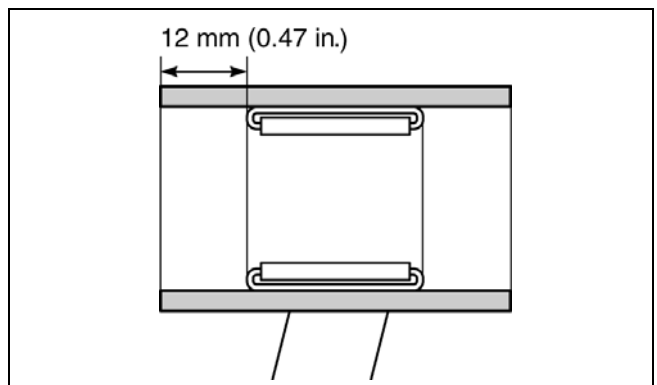

ATV2196

7

3. Coat the spacers (2) and the lips of the dust seals (3) with multipurpose grease; then install them in the upper pivot.

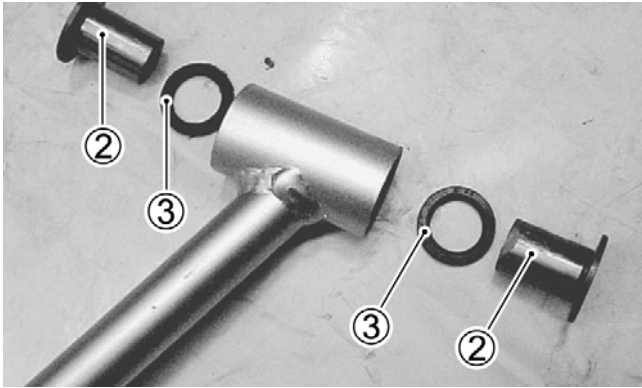

SP386

4. Install the bearing spacer (4), dust seals (5), dust covers (6), and washers (7) into the lower arm.

■ **NOTE:** The stamped mark on the dust seals must be directed to the outside.

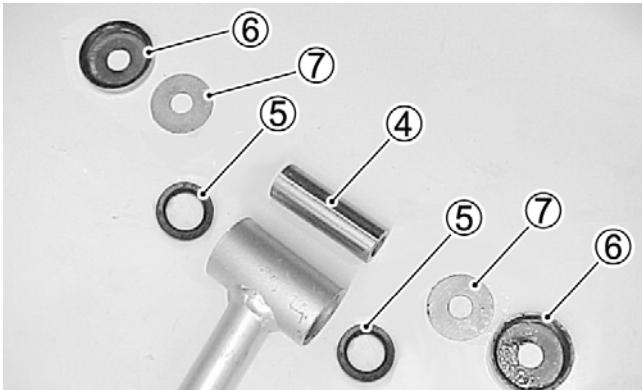

SP387

5. Clean all grease from the ball joint tapers and the knuckle bores; then install the arms to the steering knuckle and tighten the ball joint nuts to specifications. Install new cotter pins.

■ **NOTE:** During assembly, new cotter pins should be installed.

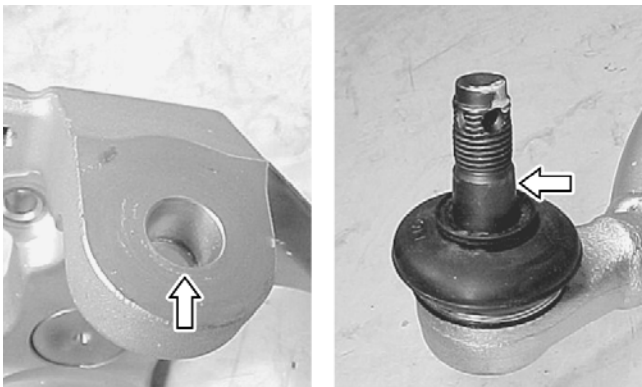

SP388A

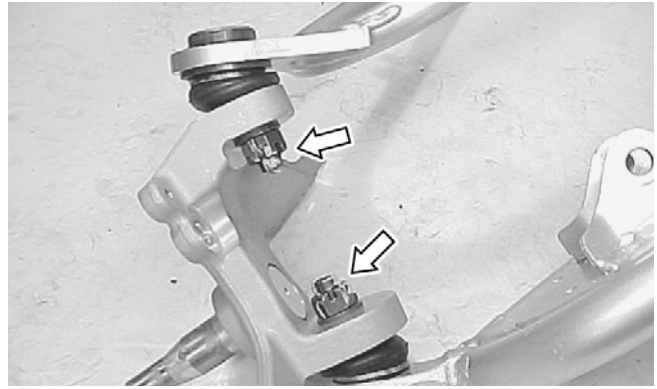

SP390

6. Install the arms to the frame with the pivot cap screws; then tighten the nuts to specifications.

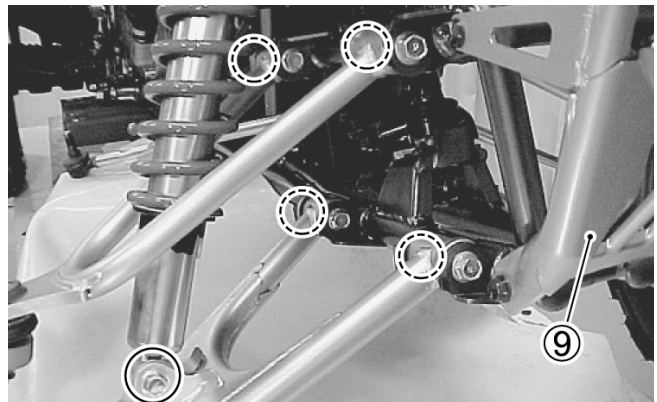

SP391

7. Install the front bumper assembly; then install the front shock absorbers. Use red Loctite #271 on the cap screw threads and tighten to specifications.



SP392

8. Apply red Loctite #271 to the mounting cap screws; then install the disc cover and tighten securely.

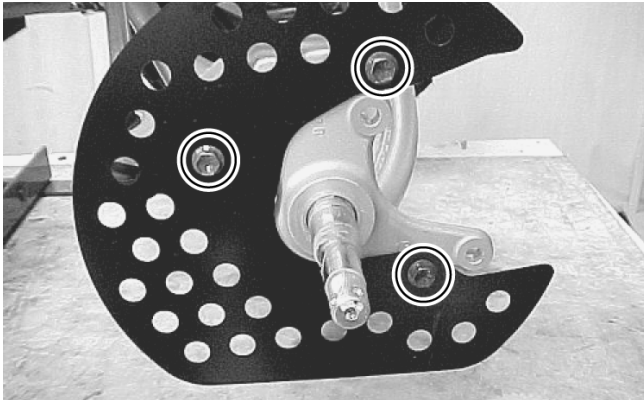

SP393

9. Connect the tie rod ends (11) to the steering knuckle (12) making sure that the washer (10) is properly located; then tighten the nut to specifications and install a new cotter pin.

■ **NOTE:** During assembly, new cotter pins should be installed.



SP394

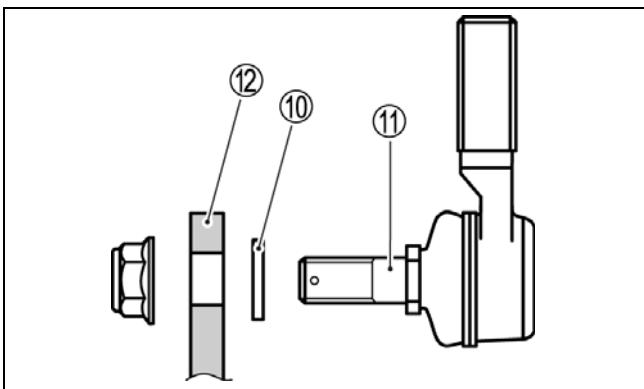

ATV2197

## Wheels and Tires

### TIRE SIZE

#### ⚠ WARNING

Use only Arctic Cat approved tires when replacing tires. Failure to do so could result in unstable ATV operation.

The ATV is equipped with low-pressure tubeless tires of the size and type listed below. Do not under any circumstances substitute tires of a different type or size.

#### ⚠ WARNING

Do not mix tire tread patterns. Use the same pattern type on front and rear. Failure to heed warning could cause poor handling qualities of the ATV and could cause excessive drive train damage not covered by warranty.

### TIRE INFLATION PRESSURE

Front and rear tire inflation pressure should be 0.30 kg/cm<sup>2</sup> (4.4 psi) front and 0.27 kg/cm<sup>2</sup> (4.0 psi) rear.

### REMOVING

1. Secure the ATV on a support stand to elevate the wheels.

#### ⚠ WARNING

Make sure the ATV is solidly supported on the support stand to avoid injury.

2. Remove the wheels.

■ **NOTE:** Keep left-side and right-side wheels separated for installing them on their proper sides.



SP054

## CLEANING AND INSPECTING

■ **NOTE:** Whenever a part is worn excessively, cracked, or damaged in any way, replacement is necessary.

1. Clean the wheels and hubs with parts-cleaning solvent.
2. Clean the tires with soap and water.
3. Inspect each wheel for cracks, dents, or bends.
4. Inspect each tire for cuts, wear, missing lugs, and leaks.

## INSTALLING

1. Install each wheel on its hub.



SP054

■ **NOTE:** Make sure each wheel is installed on its proper hub as noted in removing (the “rotation arrow” must indicate forward direction of rotation).



AF612D

2. Tighten to specifications.

## CHECKING/INFLATING

1. Using an air pressure gauge, measure the air pressure in each tire. Adjust the air pressure as necessary to meet the recommended inflation pressure.
2. Inspect the tires for damage, wear, or punctures.

### **WARNING**

**Do not operate the ATV if tire damage exists.**

■ **NOTE:** If repair is needed, follow the instructions found on the tire repair kit or remove the wheel and have it repaired professionally.

■ **NOTE:** Be sure all tires are the specified size and have identical tread pattern.

3. Check the front wheel toe-in and toe-out and adjust as necessary (see Section 8).
4. Test drive the ATV on a dry, level surface and note any pulling to the left or right during acceleration, deceleration, and braking.

■ **NOTE:** If pulling is noted, measure the circumference of the front and rear tires on the pulling side. Compare the measurements with the tires on the opposite side. If pulling is noted during braking only, check and adjust the brakes as necessary and recheck operation (see Section 2).

5. Increase the air pressure in the tires with the smallest circumference measurement until all tires are equal in circumference.
6. Repeat steps 4-5 as necessary to ensure proper handling.